

A Dual-Band Wire Beam

for 17 and 12 Meters

Allen Baker, KG4JJH

The enthusiasm generated by the Moxon¹ has left many amateurs wondering if a multi-band version is possible. Interaction between elements, however, has denied the builder an easy answer. Nevertheless, a dual-band version *is* possible for non-consecutive bands.

This wire beam Moxon antenna offers double duty on 17 and 12 meters with one 50 Ω feed line.

The Design

In one of his articles, W4RNL describes three methods of nesting Moxon rectangles that allows the antenna to retain its desirable characteristics.² (For a detailed explanation, I encourage the

reader to study this enlightening piece.) The method presented here is the first and simplest of the three versions to build. The antenna's 50 Ω feed line attaches to the 12 meter driven element, and from there a 75 Ω transmission line feeds the 17 meter driver.

The original antenna designs were based on the use of 3/4 and 1/2 inch aluminum tubing for construction, but I wanted to use wire elements, in order to allow for portable operation. Reducing the element diameter will reduce the SWR bandwidth, but this does not become an issue

¹Notes appear on page 32.

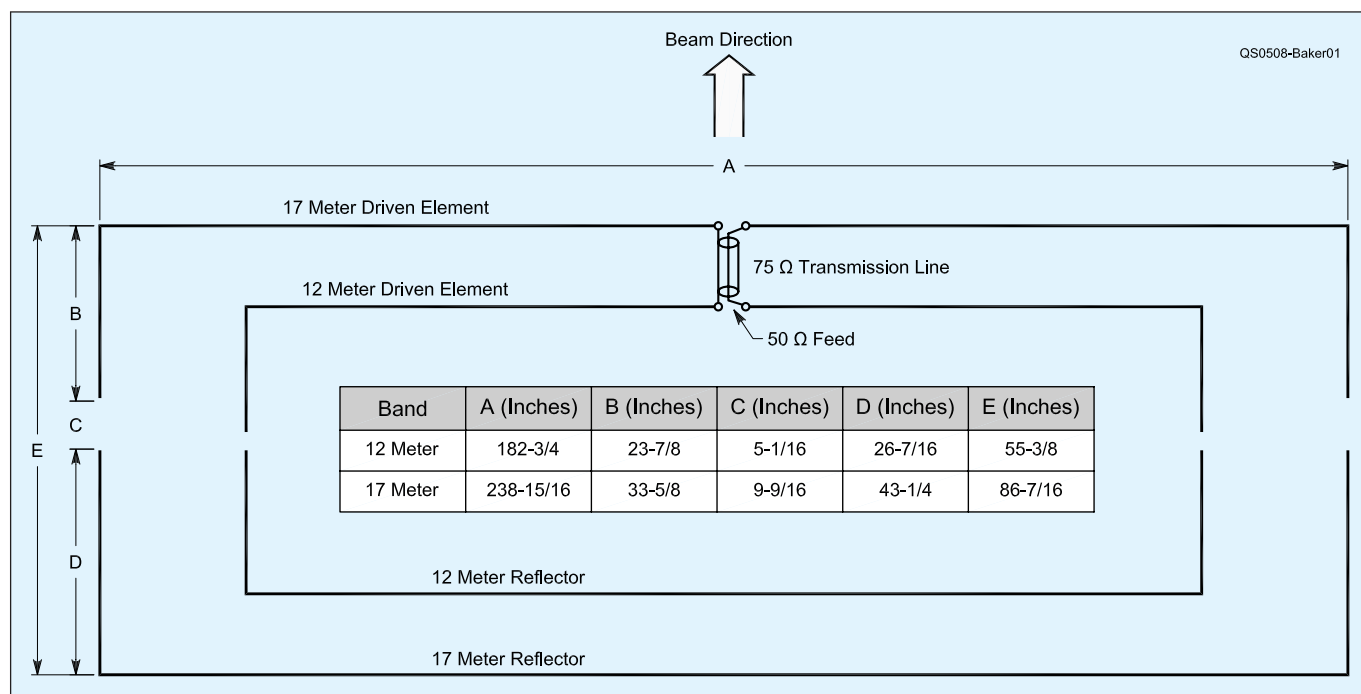

Figure 1—The dual-band Moxon antenna layout, with basic element dimensions.

for the narrow 12 and 17 meter bands. Numerous *EZNEC* modeling sessions yielded a dual-band design that appeared to equal Moxon wire monobander parameters.³ Figure 1 shows the basic antenna layout and Table 1 shows the modeled data for both free-space and 30 foot elevations. Detailed construction drawings are available at the ARRL Web site.⁴

The Hub

To ensure a rugged and weatherproof design, fiberglass spreaders are mounted on an aluminum plate using stainless steel U-bolts. A view of the center hub, together with the top guy anchoring post can be seen in Figure 2. Two die-cast aluminum flanges secure the mast to the hub on the bottom, and the guy line post on the top. The hub is made from a one-foot square of aluminum plate of 0.190 inch thickness. Using a paper template taped to the aluminum plate, center punch and drill all holes. Next, cut the plate into a circle to reduce the weight. On the top of the plate, draw a 4 inch diameter circle, in the center, with a permanent marker. This circle will be used later to align the spreaders. Four 3/8-16 x 1 1/2 inch stainless steel hex bolts and stop nuts are used to attach the flanges to the top and bottom sides of the plate. Figure 3 shows the hub bottom.

The Spreaders

The four main spreaders are made of 3/4 and 1/2 inch OD x 1/8 inch wall fiberglass tubing. A feed line spreader supports the coax and transmission line on one side, while a balance spreader pro-

vides balance and element support on the opposite side. A 12 inch piece of 1/2 inch OD tubing is inserted into one end of each 3/4 inch tubing at the hub for reinforcement. A cutting schedule is shown in Table 2.

To keep from drilling holes and weakening the spreaders, the wire elements and guy lines are attached using nylon collars.⁵ These “collars” slide over the fiberglass tubing and tighten with a setscrew. Four 1/2 inch ID collars are drilled and tapped (opposite the setscrew) to accept 1/4-20 nylon screws which are used as the 17 meter element corner anchors.

Four 3/4 inch ID collars are drilled and tapped (opposite the setscrew) to accept 1/4-20 nylon screws, which are used as the 12 meter element corner anchors. The nylon screws and collars provide a weatherproof method of securing the elements without adding metal that might affect resonance. The collars also provide an easy way to adjust the elements. A partial view of the inner element (12 meter) collars can be seen in Figure 4.

The Feed Line/Balance Spreaders

Two type-C, 1/2 inch PVC conduit bodies are mounted on the feed line spreader

Table 1
Modeled Antenna Data

Elevation	Free-Space		30 Feet	
Center Frequency (MHz)	18.118	24.94	18.118	24.94
Gain (dBi)	5.97	5.81	10.94	10.84
Front-to-Back Ratio (dB)	27.99	30.64	21.35	25.46
Complex Impedance (Ω)	45.1 - j5.3	44.4 + j12.9	48.3 - j8.9	41.6 + j12.8
SWR	1.16:1	1.35:1	1.2:1	1.4:1

Table 2
Cutting Schedule

Description	Quantity	Total Length (Inches)	Materials
Spreader reinforcement	6	12	1/2" OD fiberglass tubing*
Main spreader extension	4	48	1/2" OD fiberglass tubing*
Main spreader	4	96	3/4" OD fiberglass tubing*
Feed line spreader	1	48	3/4" OD fiberglass tubing*
Balance spreader	1	48	3/4" OD fiberglass tubing*
17 meter driver	2	153	14 gauge Flexweave wire and ring terminals
17 meter reflector	1	325 1/4	14 gauge Flexweave wire and ring terminals
17 meter insulator	2	10 5/8	Screen base (1/2" wide)
12 meter driver	2	115	14 gauge Flexweave wire and ring terminals
12 meter reflector	1	235 5/8	14 gauge Flexweave wire and ring terminals
12 meter insulator	2	6 1/8	Screen base (1/2" wide)

*All fiberglass tubing is 1/8" wall.



Figure 2—A top view of the antenna center hub during construction, together with the guy anchor post.

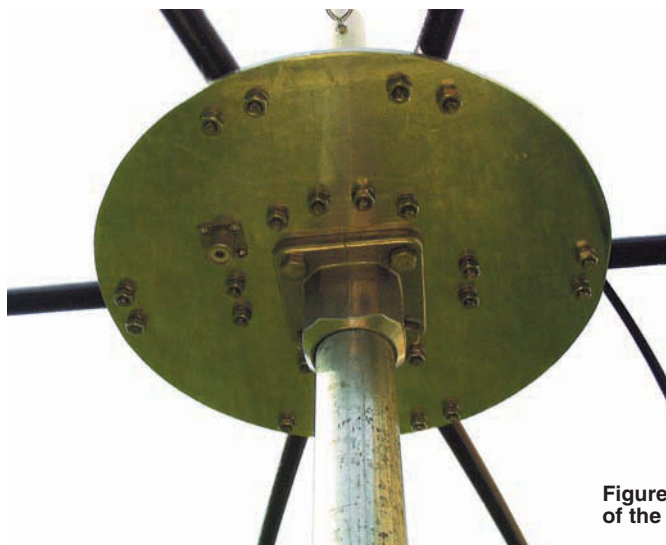

Figure 3—A bottom view of the antenna center hub.

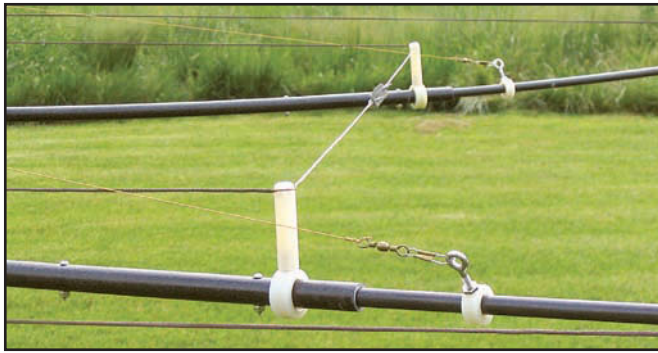

Figure 4—Element and guy anchor collars. The inner (12 meter) element collars are shown.

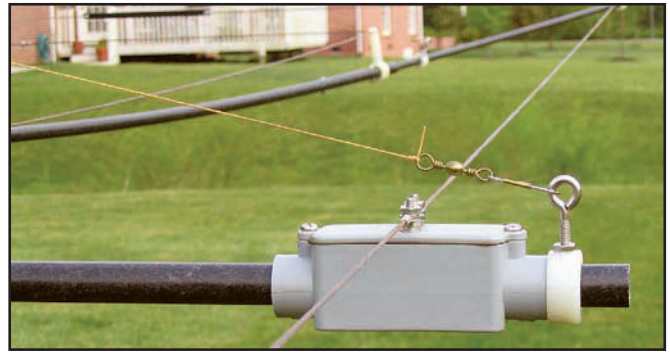

Figure 5—One of the conduit bodies. These house the transmission and phasing line junctions to the driven elements.

and provide access to the feed line, transmission line, and driven element terminal posts. The conduit bodies slide over the $\frac{3}{4}$ inch tubing and are secured with stainless steel setscrews. After you have determined the location of each conduit body, cut slots (inside the conduit bodies) on the top of the $\frac{3}{4}$ inch fiberglass feed line spreader to allow coax cable entry and exit. Two $\frac{3}{4}$ inch ID collars are mounted on the balance spreader for element support. Once again, drill and tap both collars (opposite the setscrew) to accept a $\frac{1}{4}$ -20 nylon screw. Also, drill and tap two $\frac{1}{4}$ -20 holes in the bottom of both conduit bodies for the setscrews. Figure 5 shows a close-up of one of the conduit bodies.

The Elements

The elements are cut from 14 gauge Flexweave wire, according to the cutting schedule of Table 2. One hundred feet of wire will provide enough length for both bands. The insulators are made from $\frac{1}{2}$ inch wide strips, cut from screen base (used for screened-in porches). The elements are attached to the insulators and feedpoints by crimping and soldering ring terminals to the wire ends—securing them to the insulators with #6 thread-cutting screws. You should be careful to include the lengths of the ring terminals when cutting the wire to get the correct lengths (Figure 6).

The Guy Lines

Nylon collars are drilled and tapped to accept $\frac{3}{16}$ inch stainless steel eyebolts that are used for the guy line tie points. Four $\frac{1}{2}$ inch ID collars are used for the four main spreaders and two $\frac{3}{4}$ inch ID collars for the feed line and balance spreaders. Using a combination of forces, that are provided by the guy lines and elements, the main spreaders are stressed into an “S” curve to supply the tension needed to stretch the elements taut.

Prepare the guy line post by cutting a 14 inch piece of $1\frac{1}{4}$ inch schedule 40 PVC pipe. Measure 2 inches down from the end,

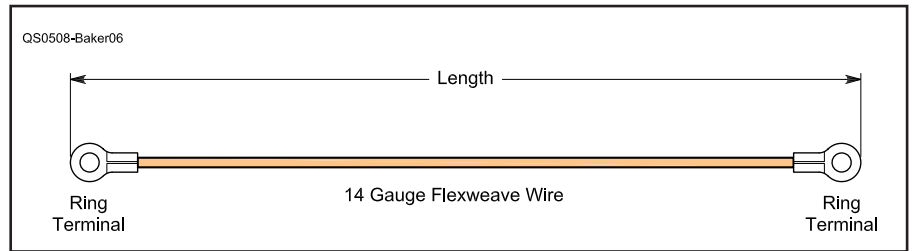

Figure 6—Be sure to include the ring terminals when measuring element length.



Figure 7—The guy wire center post, turnbuckles, and hub. Note the conduit boxes at the lower right. These serve as feed line junctions to the driven elements. The feed line and phasing line pass through the fiberglass support arm.

and drill a $\frac{1}{4}$ inch OD hole all the way through the center of the pipe. Next, measure $1\frac{5}{8}$ inches down from the same end and 90° away from the first hole, and drill a $\frac{3}{16}$ inch hole all the way through the center of the pipe. Install two $\frac{1}{4}$ inch and two $\frac{3}{16}$ inch stainless steel eyebolts with hex nuts. With the eyebolts on top, secure the pipe into the top hub-mounted flange by tightening the setscrew.

Prepare six guy lines using Kevlar twine, fishing swivels, and clips. The

Kevlar is stronger than fishing line and it will not stretch as much as nylon or polyester. The total length for the four main spreader assemblies (Kevlar length plus swivel/clips on each end) should be 96 inches. Make the feed line and balance spreader guy line assemblies 46 inches long. I used standard fishing line knots on each end and, with a little practice, I was able to get the lengths correct.

Each guy line is attached to an aluminum/stainless steel turnbuckle at the guy

line post to make adjustments easier, as shown in Figure 7. The other ends of the long guy lines attach to the four 1/2 inch OD collars with eyebolts mounted on the main spreaders, and the short guy lines attach to the two feed line/balance spreader 3/4 inch OD collars. Figure 8 shows a closeup of a typical guy line anchoring collar, together with an element support collar.

Assembly

Since I wanted to be able to disassemble the antenna, I fastened the spreaders together with screws and nuts. Insert a 48 inch long piece of 1/2 inch OD fiberglass tubing into one end of the 3/4 inch OD × 96 inch long main spreader with a 12 inch overlap. Drill two 9/64 inch OD holes through both tubes—3 inches from each overlapped end—being careful to drill straight through the centerline of the tubes and perpendicular to its surface. Secure using two 6-32 × 1 inch stainless steel screws and stop nuts at each overlap, but do not over tighten. Repeat this process for all four main spreaders.

Spread a thin bead of *Liquid Nails* on one side only (to allow moisture to drain) of each 12 inch piece of 1/2 inch OD fiberglass tubing doubler. Insert each doubler flush into one end of the four 3/4 inch OD × 96 inch long main spreaders and the two 3/4 inch OD × 48 inch long feed line/balance spreaders. Allow several days for these joints to cure because little drying air can get to the joint. Insert each reinforced spreader under a pair of hub-mounted U-bolts and align the ends with the 4 inch diameter circle marked earlier. Add stainless steel lockwashers and tighten each U-bolt until snug, being careful not to crack the fiberglass.

For convenience, mount a temporary short mast that places the hub at a comfortable working height. Slide all collars onto the spreaders and tighten the setscrews, using the dimensions on drawing sheets 3 and 5 as starting points.⁶ (These starting points are applicable only if you used identical materials as listed in the materials list on drawing sheet 5.) Remove the conduit-body top plates, and drill and mount 8-32 × 1 inch stainless steel screws, nuts, and lock washers, spaced 1/2 inch apart. You will have to remove some of the lip on the bottom of the top plate with a Dremel tool to make room for the screw heads.

Mount an SO-239 connector on the hub and route a length of 50 Ω coax (RG-8X) from there to the 12 meter conduit-body inside the feed line spreader. (The feed line spreader ID is 1/4 inch, so make



Figure 8—A typical element support collar and guy-anchoring collar.

sure your coax OD is slightly smaller.) Solder the coax to the SO-239 and, using ring terminals, attach the other side to the 12 meter feed point screws. Route a length of 75 Ω coax (RG-59, VF = 0.8) from the 12 meter feed to the 17 meter feed, inside the feed line spreader.

Using ring terminals, attach the center conductor of the 75 Ω phasing line to the left 12 meter/17 meter drivers and the braid to the right 12 meter/17 meter drivers (or vice versa). This is an important step, as reversing the phase of the transmission line between elements will negate its purpose. I added a plastic cap (fastened with RTV silicone glue) to weatherproof the back of the SO-239 connector.⁷ I recommend the use of stranded wire center conductors for both coax cables to reduce the possibility of breakage when assembling the feed lines inside the conduit bodies.

At this point you will notice that the main spreaders have started to sag. Adjust the tension in the guy lines by adjusting the turnbuckles until the tips of the main spreaders are a few inches higher than the hub. Cut the wire elements and mark each corner with a permanent marker according to the lengths in Figure 1 and Table 2. Using a soldering iron, tin a 1/8 inch wide band around each mark with solder, to permanently mark the wire element corners.

Attach the 12 meter driven element to the right feed point and route the wire around the collar-mounted nylon screw, placing the solder mark under the nylon washer and screw and tighten. (Do not over-tighten the nylon screws—I learned that the hard way. If you do twist the head off, drill a 1/16 inch hole in the remaining threaded portion, insert a #1 screw extractor, and turn counterclockwise.) The nylon washer is important—it prevents the wire element from moving as you tighten the screw. Continue, in similar fashion, to the 12 meter insulator, the 12 meter

reflector, another 12 meter insulator, and then attach the 12 meter driver to the left 12 meter feed point. The same procedure is used for the 17 meter elements.

Final collar and turnbuckle adjustments should be made in small increments—this will keep the spreaders stressed evenly and the elements level and equidistant from each other. When you are satisfied, line up the center of the feedpoints and tighten the conduit-body setscrews. If desired, trim the spreaders to within 2 inches of the collars, using a hacksaw.

I highly recommend assembling all the components, making *all* element and feed point adjustments, and then tackling the feed point wiring (and associated slot-cutting) last. Once the feed and transmission line coax has been installed in the conduit boxes, it becomes difficult to move them.

The fiberglass-tubing supplier recommends spray-painting the spreaders flat black to increase their life. First, clean them with a solvent, such as acetone. Then, use a good primer, allowing it to cure for two days. Finally, finish with a topcoat of flat black.

A 5 inch long, 1/4 inch pipe nipple was used to make the transition from the four-hole flange on the bottom of the antenna to my mast. Before you mount the antenna on the mast, check all hardware to make sure it is secure. The finished antenna—up and ready to go—can be seen in Figure 9.

Results

The complete antenna weighed in at 15 pounds, which was a bit too much for a push-up mast. I fastened the antenna to my recently acquired AB-952 military surplus mast, and raised it to a height of 30 feet. This mast is a bit cumbersome to move, but it provides a rock-steady platform for supporting antennas as high as 35 feet using 4 inch OD aluminum tubing. At this elevation, my MFJ-259B

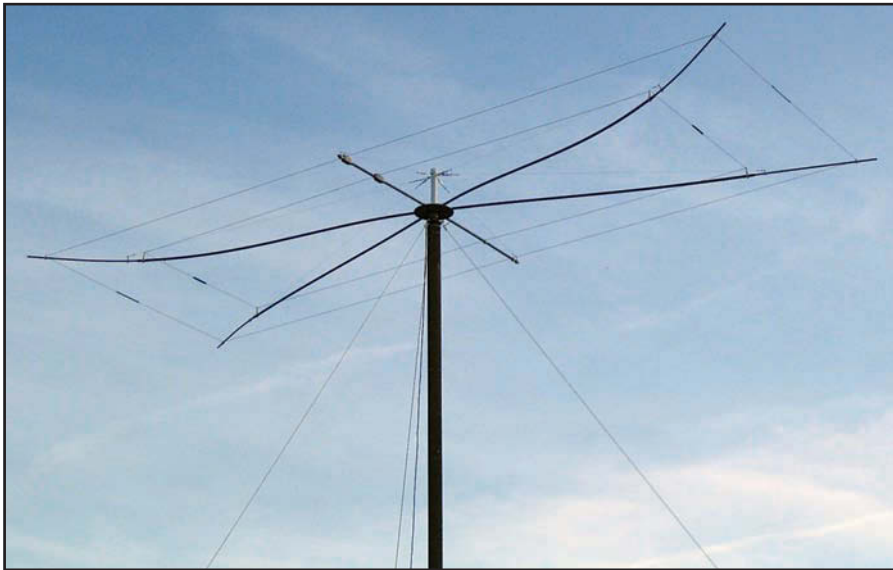

Figure 9—Are the bands open? The completed antenna ready to snag some elusive DX!

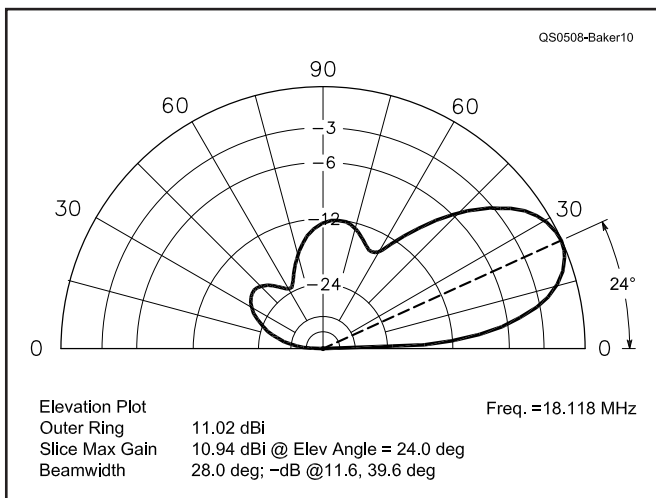

Figure 10—A modeled elevation plot of the antenna at 30 feet on 17 meters using EZNEC. The gain at 12 meters is essentially the same, except for a lower take-off angle. [Bear in mind that the antenna's gain and launch angle will be seriously affected by the local ground characteristics and the antenna's height above that ground.—Ed.]

antenna analyzer indicated that both bands were within the modeled SWR, and never exceeded 1.4:1. An elevation plot (EZNEC) of the antenna on 17 meters is shown in Figure 10. The 12 meter gain model is essentially the same, save for a lower take-off angle (18° versus 24°) at the same height. Modeled SWR at 17 meters is about 1.2:1 at the band center (18.118 MHz).

PJ2/K9LZJ on DXpedition in Curacao supplied my first contact. Using only 5 W SSB, this 1900 mile contact gave me a 5-5 report and congratulated me on my setup. KF6IWW provided the second QSO and gave me a chance to work both bands using 5 W on PSK31 and PSK63 modes. The contact ended up on 12 meter SSB using 50 W, where we had a very nice chat for over an hour. As a quick front-to-back ratio test, I pointed the beam toward a station in Ireland and ob-

served a signal strength of S-9. After rotating the antenna 180°, the meter read S-6. Using the traditional 6 dB/S-unit approximation, this worked out to 18 dB, which was 3 dB below the modeled F/B of 21 dB. With the assistance of NG4T, additional testing on both bands was performed using CW, digital, and SSB modes at power levels of 5 to 100 W.

I am delighted that the antenna is performing as well as a single-band Moxon, with excellent gain, directivity, and front-to-back ratio. The Moxon rectangle is, in my opinion, the best performer among the family of dual-coupled 2-element parasitic beams in terms of gain, front-to-back ratio, and SWR bandwidth. This dual-band version retains these characteristics in an antenna that is less than half the footprint (in square feet) and within 1 dBi (modeled) gain of a commercial dual-band 4-element Yagi.⁸

Notes

- ¹Moxon Antenna Project (www.moxonantenna-project.com).
- ²"The Elusive Moxon Nest," L.B. Cebik, W4RNL (www.cebik.com/moxon/mox1712.html).
- ³EZNEC, W7EL (www.ez nec.com/index.shtml).
- ⁴www.arrl.org/files/qst-binaries/baker0805.zip.
- ⁵Quad guy ties (www.antenna-magic.com/antenna/Product.htm).
- ⁶See Note 4.
- ⁷Both the SO-239 socket and its mating connector, the PL-259, are not waterproof. Remember to liberally wrap the plug and socket assembly and the plug cable entrance with vinyl electrical tape (Scotch 33+) or coaxial sealing tape (CoaxSeal) for any outdoor application.—Ed.
- ⁸OB4-2WARC, Optibeam (www.optibeam.de/).

All photos by the author.

Allen Baker, KG4JJH, became licensed in September 2000, after a lifelong dream of becoming a ham. Active on SSB and the digital modes, Allen enjoys experimenting with antenna designs. He has a BS in Industrial Engineering from Tennessee Technological University and is an Instrument and Controls Engineer at the BWXT Y-12 National Security Complex in Oak Ridge, Tennessee. You can reach him at kg4jjh@arrl.net. 

New Products

KEYING BUFFER AND SEQUENCER

◇ The AMPSEQUENCER is a microprocessor controlled CW buffer, amplifier and transceiver control board offered by Netcertus. The primary function of the AMPSEQUENCER is to buffer the CW paddle or straight key signals to allow amplifier relays to fully settle before transmitting. Buffering, and consequently, delay time can be adjusted from 10 to 80 ms. The radio SEND signal that controls the amplifier is monitored to maintain the semi-break-in delay set by the operator.

The AMPSEQUENCER is also equipped with a fixed 30 ms PTT-in to PTT-out delay designed to be used during digital transmissions. External electronic recording devices can also make use of this feature.

Switching is handled by open collector devices with current handling rated at 800 mA to 40 V for the amplifier and PTT-out. The CW key and pre-out lines are rated at 400 mA, also at 40 V. The unit is priced at \$35. For more information, see ampsequencer.netcertus.com.

